

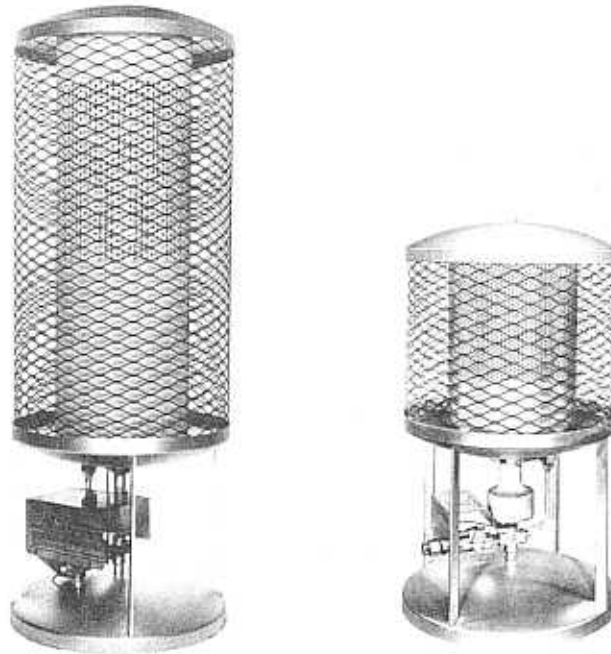

INSTALLATION AND OPERATING INSTRUCTIONS

FLOOR MODELS RFPA10B and RFPA21A



WHAT TO DO IF YOU SMELL GAS

- * Do not try to light any appliance.
- * Do not touch any electrical switch; do not use any phone in your building.
- * Immediately call your gas supplier from a neighbors phone. Follow the gas supplier's instructions.
- * If you cannot reach your gas supplier, call the fire department.

WARNING: Improper installation, adjustment, alteration, service or maintenance can cause property damage, injury or death. Read the installation, operating and maintenance instructions thoroughly before installing or servicing this equipment.

SAVE FOR FUTURE REFERENCE

Space Ray Division, Gas Fired Products, Inc. P.O. Box 36485, Charlotte, NC 28236 (704) 372-3485

TABLE OF CONTENTS

<u>SECTION</u>	<u>DESCRIPTION</u>	<u>PAGE NO.</u>
1	General Information	1
2	Specifications	2
3	Adding Optional Reflector	2
4	Minimum Clearances to Combustibles	3
5	Gas Connections and Regulation	3
6	Instructions for Pressure Test Gauge Connection	3,4
7	Information for LP Gas Floor Models Only	4,5
8	Ventilation and Combustion Air	5
9	Lighting and Shutdown Instructions	5,6
10	Cleaning and Annual Maintenance	6
11	Replacing Parts	6
12	Replacement Parts List & Guide	7,8

1. GENERAL INFORMATION

INSTALLER: This manual is the property of the owner. Please present this manual to the owner when you leave the jobsite.

This heater is a self-contained infrared radiant floor model heater for use in locations where flammable gases or vapors are not generally present and is intended for the heating of non-residential spaces.

INSTALLATION REQUIREMENTS

Installation of this heater must be in accordance with all applicable codes shown in the instructions and/or the local codes and authorities having jurisdiction. Heaters shall be installed by a licensed contractor or licensed installer. Clearances to combustibles as outlined in this manual should always be observed.

Every heater shall be located with respect to building construction and other equipment so as to permit access to the heater. Each installer shall use good installation practices when locating the heater and must give consideration to service accessibility.

This heater is certified by the American Gas Association Laboratories as a space heater only and should not be used for any other applications.

This heater is for **INDOOR INSTALLATION ONLY**. While the products of combustion are expelled into the building, national codes require ventilation in the building to dilute these products of combustion. This ventilation may be provided by gravity or mechanical means. Refer to Section 8 of this manual for minimum requirements for ventilation and combustion air.

Copies of the National Fuel Gas Code (ANSI Z223.1 - latest edition) are available from the American Gas Association Laboratories, 8501 E. Pleasant Valley Road, Cleveland, OH 44131. All NFPA codes are available from the National Fire Protection Association, Batterymarch Park, Quincy, MA 02269.

NOTE: This heater does not comply with Section 2.10 Radiant Coefficient of ANSI Z83.6a - 1992.

WARNING: DO NOT move, handle or service a hot or operating heater.

WARNING: Heaters must only be used on stable and level surfaces for safe operation.

2. SPECIFICATIONS

MODEL NO.	GAS TYPE	INPUT BTU/HR	ORIFICE SIZE
RFPA10B	NATURAL	100,000	#12 (.1890)
RFPA10B	PROPANE	95,000	7/64 (.1094)
RFPA21A	NATURAL	212,000	"H" (.2660)
RFPA21A	PROPANE	200,000	#20 (.1610)

Gas Pipe connection: ½" NPT Female

MODEL SUFFIXES:

- N - Natural Gas
- L - Propane Gas
- 6 - Standing Pilot Ignition
100% Safety Shutoff, Manual Valve (Baso)
- 6C - Standing Pilot Ignition
100% Safety Shutoff, Manual Valve (White-Rodgers)

DIMENSIONS	RFPA10B	RFPA21A
HEATER	18" Dia. x 32-3/4"	18" Dia. x 48-9/16"
PACKAGED	18-1/2" x 18-1/2" x 34"	18-1/2" x 18-1/2" x 51-1/2"
SHIPPING WEIGHTS	55 LBS.	62 LBS.

3. ADDING OPTIONAL REFLECTOR

A 180° reflector can be used where it is desirable to direct the heat into a specific work area. This is ordered as an accessory item, Part No. 0431003 for Model RFPA10B or Part No. 0431001 for Model RFPA21A.

INSTALLATION INSTRUCTIONS

1. Loosen and remove the 1/2-13 hex nut and washer from the heater assembly.
2. Lift the head from the heater.
3. Place reflector on outside of expanded metal guard with bottom edge inside lip of the base head assembly.
4. Replace upper head with lip over the expanded guard and reflector.
5. Resecure with the nut and washer.

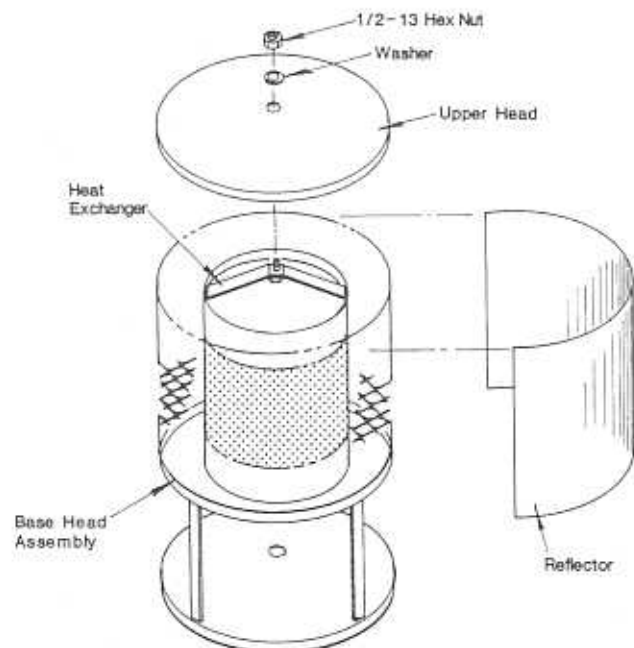

4. MINIMUM CLEARANCES TO COMBUSTIBLES

The heater shall be operated only on a **NON-COMBUSTIBLE**, level floor. Minimum clearances to combustible walls and ceilings are listed below:

MODEL RFPA10B	FRONT	SIDES	REAR	TOP	CLEARANCE FROM PROPANE CYLINDER
WITH REFLECTOR	120"	60"	48"	54"	20 FEET
WITHOUT REFLECTOR	----	60"	----	54"	20 FEET

MODEL RFPA21A	FRONT	SIDES	REAR	TOP	CLEARANCE FROM PROPANE CYLINDER
WITH REFLECTOR	240"	84"	48"	54"	20 FEET
WITHOUT REFLECTOR	----	144"	----	54"	20 FEET

REFER TO BULLETIN NFPA 58 AND LOCAL CODES

WARNING: KEEP PERSONNEL AND COMBUSTIBLE MATERIAL AT LEAST 5 FT. FROM HEATER MODEL RFPA10B AND AT LEAST 12 FT. FROM HEATER MODEL RFPA21A WHEN IN OPERATION.



5. GAS CONNECTIONS AND REGULATION

1. Connect to the supply tank or manifold in accordance with the latest edition of National Fuel Gas Code (ANSI Z223.1) and local building codes. Authorities having jurisdiction should be consulted before the installation is made.
2. Pipe joint compounds must be resistant to the action of liquefied petroleum gases.
3. Where local codes do not prohibit, an A.G.A. or U.L. approved flexible connection is recommended between the rigid piping and the heater. A union and an approved shut-off valve should be installed before the control valve inlet. The shut-off valve should be installed within 6 feet of the union.
4. This appliance is equipped with a manual gas valve and an appliance regulator. The maximum supply pressure to the appliance is 14" W.C. or ½ P.S.I. If the line pressure is more than the maximum supply pressure, then use a line regulator which corresponds to the supply pressure.
5. After gas connections have been made, make sure the heater and all gas outlets are turned off before the main gas supply is turned on. Turn the gas pressure on and check for leaks. To check for leaks, apply a solution of soap suds to all connections and joints or check by one of the methods listed in Appendix D of ANSI Z223.1 (latest edition) Natural Fuel Gas Code. DO NOT USE AN OPEN FLAME OF ANY KIND TO TEST FOR LEAKS.

6. INSTRUCTIONS FOR PRESSURE TEST GAUGE CONNECTION

Supply Pressure: Installer to provide a 1/8" N.P.T. plugged tapping, accessible for test gauge connection immediately upstream of the gas supply connection to the heater.

Manifold Pressure: Turn gas valve to "OFF" position. Remove 1/8" plug from manifold downstream from the valve and connect 1/8" nipple to the tapped hole. Connect gauge to nipple. Turn on the gas supply.

With the main burner operating, check burner manifold pressure using a water manometer. If adjustment is required, remove cover screw of the appliance regulator. Using a small screwdriver, turn adjustment screw clockwise  to increase or counter-clockwise  to decrease gas pressure to burner. Replace cover screw.

Gauges which measure in pounds per square inch or ounces per square inch are not accurate enough to measure or set the manifold pressure. Use a water manometer.

GAS TYPE	MANIFOLD PRESSURE	SUPPLY PRESSURE	
		MINIMUM*	MAXIMUM
Natural	3.5" W.C.	5" W.C.	14" W.C.
Propane	10" W.C.	11" W.C.	14" W.C.

*Minimum permissible gas supply pressure for purpose of input adjustment.

7. INFORMATION FOR LP GAS FLOOR MODEL HEATERS ONLY

Heaters used with LP gas must be installed in accordance with the latest edition of the National Fuel Gas Code - NFPA54, Standard for the Storage and Handling of LP Gas - NFPA 58, all state and local codes or the authority having jurisdiction.

This heater is intended for industrial or construction heating and it must never be used for residential/domestic heating.

WARNING: A single stage regulator must be installed on the tank or cylinder to reduce the tank or cylinder pressure to the heater. Operation of this heater without this regulator can cause damage to the heater and personal injury.

The heater must be connected to the tank or cylinder by a UL Listed hose assembly or hard piping. A 15 foot assembly of UL Listed hose is available from Space-Ray under Part No. 4203500. A single stage LP gas regulator (operation range: 10-150 PSIG inlet and 11.0" W.C. outlet) having a POL fitting with an excess flow valve is available as Part No. 0345600 (LP Cylinder Kit).

The volume of a given quantity of liquid LP gas in a container is directly related to its temperature. As a result, the vaporization rate of a tank or cylinder will decrease as the temperature drops and as the percentage of liquid in the container becomes smaller. Table 1 shows the approximate vaporization rate of a 100 lb. cylinder. **CAUTION:** Space-Ray DOES NOT recommend the use of a 100 lb. cylinder with the RFP21A heater because of the large BTU input.

TABLE 1
Maximum Continuous Draw in BTU/Hr
At Various Temperatures (°F)

Lbs. of Propane in Cylinder	20°F	40°F	60°F	70°F
100	167,000	214,000	277,000	300,000
80	137,000	180,000	214,000	236,000
60	109,000	140,000	176,000	197,000
40	**	105,000	131,000	141,000
30	**	**	107,000	118,000

** Rate of vaporization drops below the heater input rate.

WARNING: Due to the continuous length of time the heater might be in operation, a 100 lb. LP gas cylinder may not be sufficient in size. Manifolding several cylinders together is a practical way of increasing the time of operation of these heaters. Operation of the heater with insufficient sized cylinders or when the liquid level becomes too low will result in poor heater performance and can cause sooting. Consult your LP gas dealer for proper sizing of container.

Always turn the gas off at the tank or cylinder when the heater is not in use. When in operation, keep the heater a safe distance from the LP gas container and combustible materials as indicated on the heater and in the instructions. Fasten LP cylinders securely so they cannot be knocked over.

8. VENTILATION AND COMBUSTION AIR

This heater requires ventilation in the building to dilute the products of combustion and provide fresh air for efficient combustion. The minimum recommended vent flow required is as follows:

RFP10B:	418 cfm
RFP21A:	880 cfm

The combustion air enters through the heater base and must not be restricted. **DO NOT** block or enclose any part of the heater base. All ventilation in the building must be at a level above the height of the heater.

9. LIGHTING AND SHUTDOWN INSTRUCTIONS

MODELS WITH IGNITION SUFFIX "-6"

1. Pull lock button and turn valve handle to "Pilot" position; **DO NOT** pull out valve handle - Push down button and light pilot. Hold button in firmly for approximately 30 seconds or until pilot remains lighted without holding button down. If air is in the line, it will take a few minutes for gas to reach the pilot.
2. Turn handle to "ON" position.
3. If heater does not light, shut off gas completely for five minutes before attempting to relight.
4. To turn off main burner and pilot gas, pull lock button and turn handle to "OFF".

CAUTION: DO NOT PULL OUTWARD ON VALVE HANDLE

MODELS WITH IGNITION SUFFIX "-6C"

1. Turn gas control knob to "OFF" position. Allow 5 minutes for any gas to escape before lighting.
2. Turn gas control knob to "PILOT" position. Push down on gas control knob and light the pilot with a match. Hold this knob down for approx. 60 seconds after lighting the pilot.
3. When the gas control knob is released, the pilot should continue to burn. If the pilot goes out, repeat Steps 1 and 2 again.
4. Push the knob down slightly and rotate the gas control knob from "PILOT" to "ON". The main burner will ignite.
5. If the main or pilot burners extinguish, depress and turn the gas control knob to the "OFF" position, wait 5 minutes and repeat the above lighting procedure.

CAUTION: DO NOT OPERATE MAIN BURNER AT ANY SETTING LESS THAN FULL "ON" POSITION. SOOTING WILL OCCUR!

"WHITE-RODGERS" VALVE

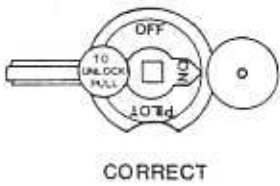

CORRECT



INCORRECT



CORRECT



INCORRECT

10. CLEANING AND ANNUAL MAINTENANCE

This heater must be cleaned and serviced at least once before the start of each heating season or at any time the infrared emitter show signs of collecting any foreign material on its surface. Maximum heating efficiency and clean combustion will be maintained by keeping the emitter and burner clean. To clean the heater follow these instructions:

1. Turn off the gas supply to the heater.
2. Remove and clean the burner.
 - a. Remove the three (3) piece burner alignment brackets.
 - b. Unscrew the burner from burner fitting on which it is mounted.
 - c. Remove three (3) fillister head screws holding burner cap in place.
 - d. Burner ports are formed by grooves on underside of burner cap; burner ports may be cleaned with a wire brush.
 - e. Removal of burner cap also makes mixing tube of burner accessible for cleaning with a round wire brush.
 - f. After cleaning, re-assemble burner cap on burner base with the three (3) 8 - 32 fillister head screws.
 - g. Screw burner all the way down on burner fitting and install burner alignment brackets.
3. If the emitter shows any accumulation of material in the ports, remove the heater top and the expanded metal guard to expose the emitter and use a high pressure air hose to blow the ports clean. If this does not clean the holes, remove the four (4) screws holding the emitter to its mounting ring and remove the emitter so that it can be cleaned both inside and out with a wire brush and then blown out with a high pressure air hose.
4. Inspect the pilot burner and remove any foreign material with a brush or an air hose.
5. Reassemble the heater, test all connections for leaks and test the heater to be sure it is now operating properly.

11. REPLACING PARTS

At all times when parts are being replaced, ensure that both gas and electrical supplies are disconnected.

Various parts are available from the factory for replacement by a licensed service person. Refer to exploded parts guide in Section 12 for all replacement parts.

Date of Installation _____

Heater Model Number RFPA _____ - _____

Heater Serial Number _____

N = Natural Gas

L = Propane Gas

12. REPLACEMENT PARTS LIST - RFPA10B & RFPA21A

ITEM NO.	PART NO.	DESCRIPTION	MODEL USED ON
1	0411400	Upper Head	
2	0459302	Expanded Metal Guard (Short)	RFPA10B
3	0459303	Expanded Metal Guard (Tall)	RFPA21A
4	0436202	Heat Exchanger Assembly (Short)	RFPA10B
5	0448500	Heat Exchanger Assembly (Tall)	RFPA21A
6	0438000	Main Burner Assembly (Complete)	
7	4185800	Burner Base	
8	4185900	Burner Cap	
9	0409401	Shutter Plate - Fixed	
10	4058400	Burner Alignment Bracket Assembly	
11	0478301	Base Assembly	
13	4180600	Warning Plate	
14	4179502	Pilot Shield - Outer	RFPA10B
15	4179501	Pilot Shield - Inner	RFPA10B
16	0339902	Pilot Burner & Orifice Fitting - Nat. #J129DDA3223	RFPA10B-N6,N6C
17	0339903	Pilot Burner & Orifice Fitting - LP #J129DDA4212	RFPA10B-L6,L6C
18	0334501	Pilot Orifice - Nat (.023") #Y90AA - 3223	RFPA10B-N6,N6C
19	0334502	Pilot Orifice - LP (.012") #Y90AA - 4212	RFPA10B-L6,,6C
20	0343700	Pilot Burner less Orifice #J129DDA	RFPA10B
21	3033501	Pilot Burner & Orifice Fitting - Nat. #J181EKA3223	RFPA21A-N6
22	3033502	Pilot Burner & Orifice Fitting - LP #J181EKA4214	RFPA21A-L6
23	0334501	Pilot Orifice - Nat (.021") #Y90AA - 3223	RFPA21A-N6
24	0334506	Pilot Orifice - LP (.014") #Y90AA - 4214	RFPA21A-L6
25	3033500	Pilot Burner less Orifice #J181EKA	RFPA21A
26	0340103	Thermocouple	RFPA10B,RFPA21A
27	0465900	Pilot Tubing - Baso valve	
28	4179900	Pilot Tubing - White-Rodgers valve	
29	0352700	Break Away Fitting - Comes w/Valve and Pilot Orifice	
32	0333902	Plug - 1/8" (Pressure Tap)	
33	4183400	Burner Fitting Assembly	
34	0325812	Main Burner Orifice (Nat.) #12	RFPA10B-N6,N6C
35	0325891	Main Burner Orifice (LP) 7/64"	RFPA10B-L6,L6C
36	0325898	Main Burner Orifice (Nat.) "H"	RFPA21A-N6
37	0325820	Main Burner Orifice (LP) #20	RFPA21A-L6
38	0369500	Gas Valve - Baso #H43BA-5D	
39	3009101	Gas Valve - White-Rodgers #764-2	RFPA10B Only
40	0330710	Regulator - RV48 (Nat.)	
41	0330721	Regulator - RV48 (LP)	
41a	0330723	Regulator - RV48 (Nat.) @ 6" W.C.	RFPA21A-N6 Only
42	0333304	Nipple 1/2 x 1-1/2	
43	0333310	Nipple 1/2 x 3	RFPA10B-N6C, L6C Only
44	0306800	Union (Complete)	Accessory Only
45	0306803	Nut (Union)	Accessory Only
46	0306801	Union Half - Female	Accessory Only
47	0306802	Union Half - Male	Accessory Only
48	4313600	Manifold Support & Nameplate Bracket	
49	4135701	Instruction Manual (Not Shown)	
50	4198800	Nameplate (State Gas Type)	RFPA10B-6
51	4198801	Nameplate (State Gas Type)	RFPA10B-6C
52	4187402	Nameplate (State Gas Type)	RFPA21A-6
53	4291801	Pilot Shield - Inner	RFPA21A
54	4291802	Pilot Shield - Outer	RFPA21A
57	0212715	Nut - Hex 1/2-13	
58	0212916	Washer - Flat 1/2	
59	4184700	Washer - Burner Fitting	
60	0224701	Machine Screw 1/2-13 x 1	
61	4187701	Control Arm Kit - Nat.	RFPA10B-N6
62	4187702	Control Arm Kit - LP	RFPA10B-L6
63	4187704	Control Arm Kit - Nat.	RFPA21A-N6
64	4187705	Control Arm Kit - LP	RFPA21A-L6
65	4187723	Control Arm Kit - Nat.	RFPA10B-N6C
66	4187724	Control Arm Kit - LP	RFPA10B-L6C

MODEL NUMBER SUFFIXES

- N - Natural Gas
- L - LP Gas
- 6 - 100% Gas Shutoff Control - Manually Operated (Baso valve)
- 6C - 100% Gas Shutoff Control - Manually Operated (White-Rodgers valve)

IMPORTANT

**PLEASE ORDER BY PART NUMBER - NOT BY ITEM NUMBER.
ALSO REFER TO COMPLETE MODEL NUMBER WHEN ORDERING.**

ALL REPLACEMENT PART PRICES AVAILABLE WHEN ORDERING.

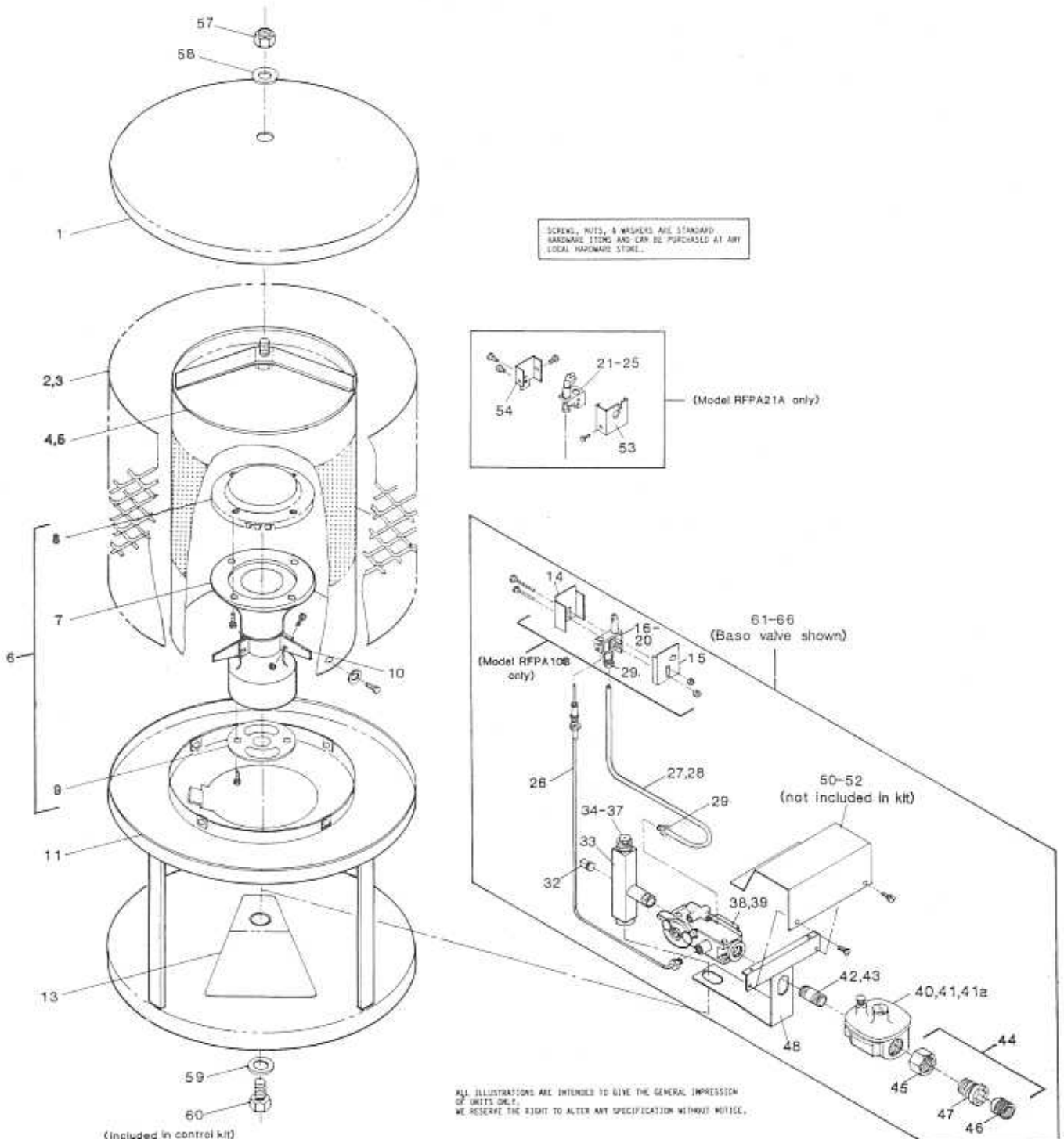



LIMITED WARRANTY: Gas-Fired Products, Inc., the manufacturer, warrants to the original owner of any Space-Ray infrared gas heater that said heater will be free from defects in material or workmanship under normal use and service. The heater(s) shall be installed, used and maintained strictly in accordance with the manufacturer's instructions. The manufacturer's sole obligation under this warranty shall be limited to furnishing replacement parts, F.O.B. Charlotte, NC, for 12 months from the date of installation, or 18 months from the date of shipment by the manufacturer, whichever period shall expire first. Labor charges for removal of defective parts and the installation of the replacement parts are not included. This warranty applies only within the USA and Canada.

WARNING: Manufacturer's warranty shall not apply: (a) to damage to the heater when used in an atmosphere containing halogenated hydrocarbons or other corrosive chemicals. Some compounds in the air can be ingested into the equipment and can cause an accelerated rate of corrosion of some of the parts of the heating components. The use of such chemical compounds in or near the operating environment of the heater should be avoided where a longer heater life is desirable; (b) to any heater or components which have been repaired or replaced with other than factory parts, modified in any way, misused or damaged, or which have been used contrary to the manufacturer's written instructions. Replacement parts are available through Space-Ray representatives or their distributors.

LIMITATION OF WARRANTY: THERE ARE NO WARRANTIES, EXPRESS OR IMPLIED, WHICH EXTEND BEYOND THE DESCRIPTION ON THE FACE HEREOF. WITHOUT LIMITING THE FOREGOING, THE MANUFACTURER EXPRESSLY EXCLUDES ANY AND ALL IMPLIED WARRANTIES, INCLUDING BUT NOT LIMITED TO ANY IMPLIED WARRANTY OF FITNESS FOR A PARTICULAR PURPOSE AND ANY IMPLIED WARRANTY OF MERCHANTABILITY FOR ITS PRODUCTS.

If any provision of this warranty is found to be void, unenforceable or unconscionable, then the same is hereby severed and the remainder of this warranty is hereby saved and shall remain in force.

EXCLUSIVE REMEDY: The sole and exclusive remedy under this warranty is the replacement of the defective parts or heaters as hereinabove specified. THE MANUFACTURER DOES HEREBY EXPRESSLY EXCLUDE ANY AND ALL LIABILITY FOR INCIDENTAL AND CONSEQUENTIAL DAMAGES UNDER THIS OR ANY OTHER WARRANTY. Without intending to limit the aforesaid exclusion, THE MANUFACTURER DOES HEREBY EXCLUDE ANY LIABILITY UNDER THIS OR ANY OTHER WARRANTY FOR INJURIES AND COMMERCIAL LOSSES TO PROPERTY THAT RESULT FROM THE OPERATION, PROPER OR IMPROPER, OF ITS PRODUCTS.

ADDITIONAL WARRANTY ON HEAT EMITTING SURFACE AND BURNER: Manufacturer warrants to the original owner of any CSA design certified heater that, if installed, used and maintained strictly in accordance with the printed instructions received with the heater, the manufacturer will at any time during the below listed time periods, furnish at no cost to the original owner, replacement emitters or burners which have become inoperative by reason of any defect in our workmanship, materials or construction. The manufacturer's obligation under this warranty shall be limited to furnishing replacements under the following time periods from the date of installation:

	<u>EMITTER</u>	<u>BURNER</u>
RFPA SERIES	1 Year	10 Years

The manufacturer will not be responsible for labor charges incurred for removal or installation of emitters. Any transportation charges involved in the return or repair are excluded.

ADDITIONAL TERMS: Manufacturer assumes no liability for delay in performing its obligations under the aforesaid warranty. Manufacturer assumes no liability for failure in performing its obligations thereunder if failure results directly or indirectly from any cause beyond its control, including but not limited to acts of God, acts of Government, floods, fires, shortages of materials, strikes and other labor difficulties or delays or failures of transportation facilities.

THIS IS A NON-RESIDENTIAL PRODUCT. Installation and service shall be by a Licensed Contractor and in accordance with National and Local Codes.

When presenting warranty claims, proof of date of purchase must be submitted.

No Representative is authorized to assume for the manufacturer any liability except as set forth above.

In case of claim under this warranty, contact:
 Space-Ray
 P.O. Box 36485
 305 Doggett Street (28203)
 Charlotte, NC 28236
 (704) 372-3485