

Ordinary ball valves are unsuitable as control devices

In order to ensure good stability of control, a hydraulic final controlling element must possess a flow characteristic that supplements the non-linear characteristic of the heat exchanger in the HVAC system.

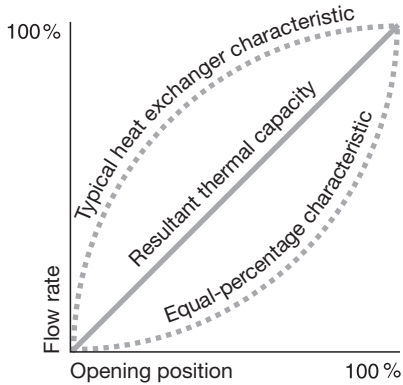

Characteristics of an ideal hydraulic final controlling element

An equal-percentage valve characteristic is desirable in order to produce a linear relationship between the thermal output and the opening position of the final controlling element. This means that the flow rate increases very slowly as the final controlling element begins to open.

Unfortunately, this characteristic is severely distorted in ordinary ball valves.

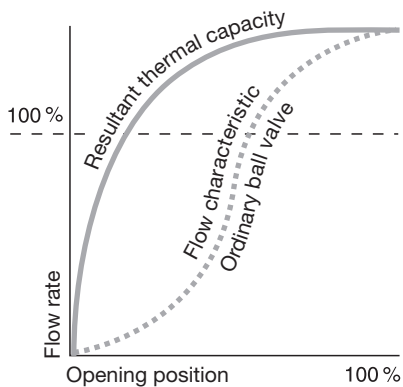

Characteristic of an ordinary ball valve

The reason for this is that an ordinary ball valve has an extremely high flow coefficient (k_{VS} value) compared with its nominal size, several times that of a comparable globe valve.

Therefore, an ordinary ball valve is not very suitable for performing control functions:

- Flow coefficient excessive due to the design
- Flow control inadequate in the part-load range

Belimo adds "characterized control" to ball valves

Belimo has succeeded in solving the problem of the distorted flow characteristic of ordinary ball valves.

A so-called "characterizing disc" in the inlet of the characterized control valve converts the valve's characteristic to the equal-percentage kind. The side of the characterizing disc facing the ball is concave and in contact with the surface of the ball. Thus, the actual flow is regulated by the hole in the ball and by the V-shaped aperture in the characterizing disc.

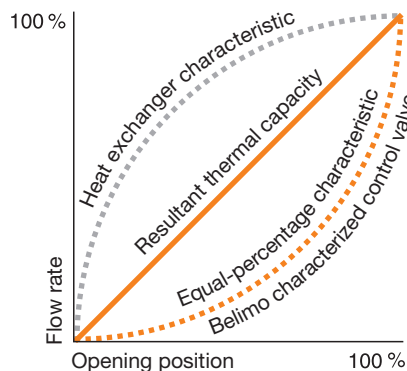

Characteristic of a Belimo characterized control valve

The k_{VS} value is reduced and corresponds approximately to that of a globe valve of comparable size. In order to avoid having to fit pipe reducers in the majority of cases, each valve size is also available with an appropriate choice of k_{VS} values.

Advantages of the Belimo characterized control valve

- Equal-percentage characteristic
- No initial jump in flow on opening
- Excellent stability of control thanks to the characterizing disk

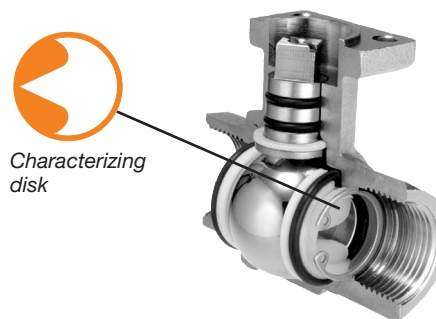

- k_{VS} values similar to those of globe valves of comparable size
- Fewer pipe reducers needed
- Less prone to vibration, greater stability of control
- Tight-sealing (2-way)

Elements of the characterized control valve

- 1 Simple direct mounting using a central screw. The rotary actuator can be mounted in four different positions
- 2 Square stem head for form-fit attachment of the rotary actuator
- 3 Identical mounting flange for all sizes
- 4 Stem with two O-ring seals for a long service life
- 5 Ball and stem made of stainless steel

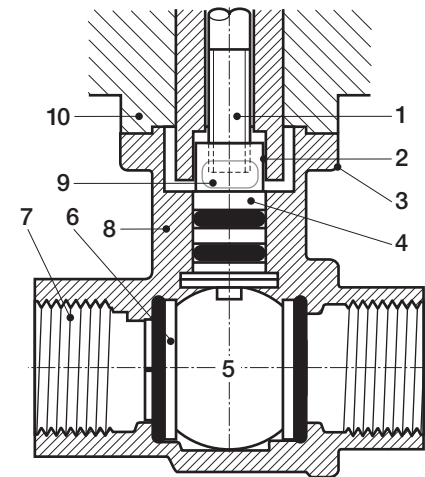

- 6 Characterizing disc produces equal-percentage flow characteristic
- 7 Internal thread connection (ISO 7/1)
- 8 Forged fitting, nickel-plated brass body
- 9 Vent window to prevent the accumulation of condensation
- 10 Thermal decoupling of the actuator from the ball valve

Optimum choice of k_{VS} valves of identical size

- Better controllability
- Lower installation costs

The Belimo range of characterized control valves includes 2-way and 3-way types. These are available in a variety of sizes and with a choice of k_{VS} values.

A characterized control valve is supplied as a unit complete with a suitable Belimo rotary actuator.